

RUBBER / NYLON

WHITE HORSE
SUPER WHEEL



SERIES

Size: 2"-3" Load: 30-40 kg



F/NL/S



F/RB/SB

F/RB/S

F/RB/STB

F/RB/ST



F/RB/X

F/NL/X

F/NL/XB



F/RB/XB

www.whitehorsecaster.com





SERIES RUBBER

**WHITE HORSE
SUPER WHEEL**



Size: 2"-3" Load: 30-40 kg

คุณสมบัติ

- สำหรับงานเบาที่ต้องการล้อที่มีขนาดเล็ก เช่น งานประกอบของเฟอร์นิเจอร์ต่างๆ สามารถประยุกต์ได้หลายอย่าง เนื่องด้วยขนาดเล็ก
- ล้อยางผลิตจากยางธรรมชาติ คุณภาพสูง เหนียวทน ไม่หลุดล่อนง่าย หรือ กรอบแตก มีให้เลือกทั้งล้อยางสีดำ และล้อไนลอน (Nylon) สีขาว

Double Ball Bearing

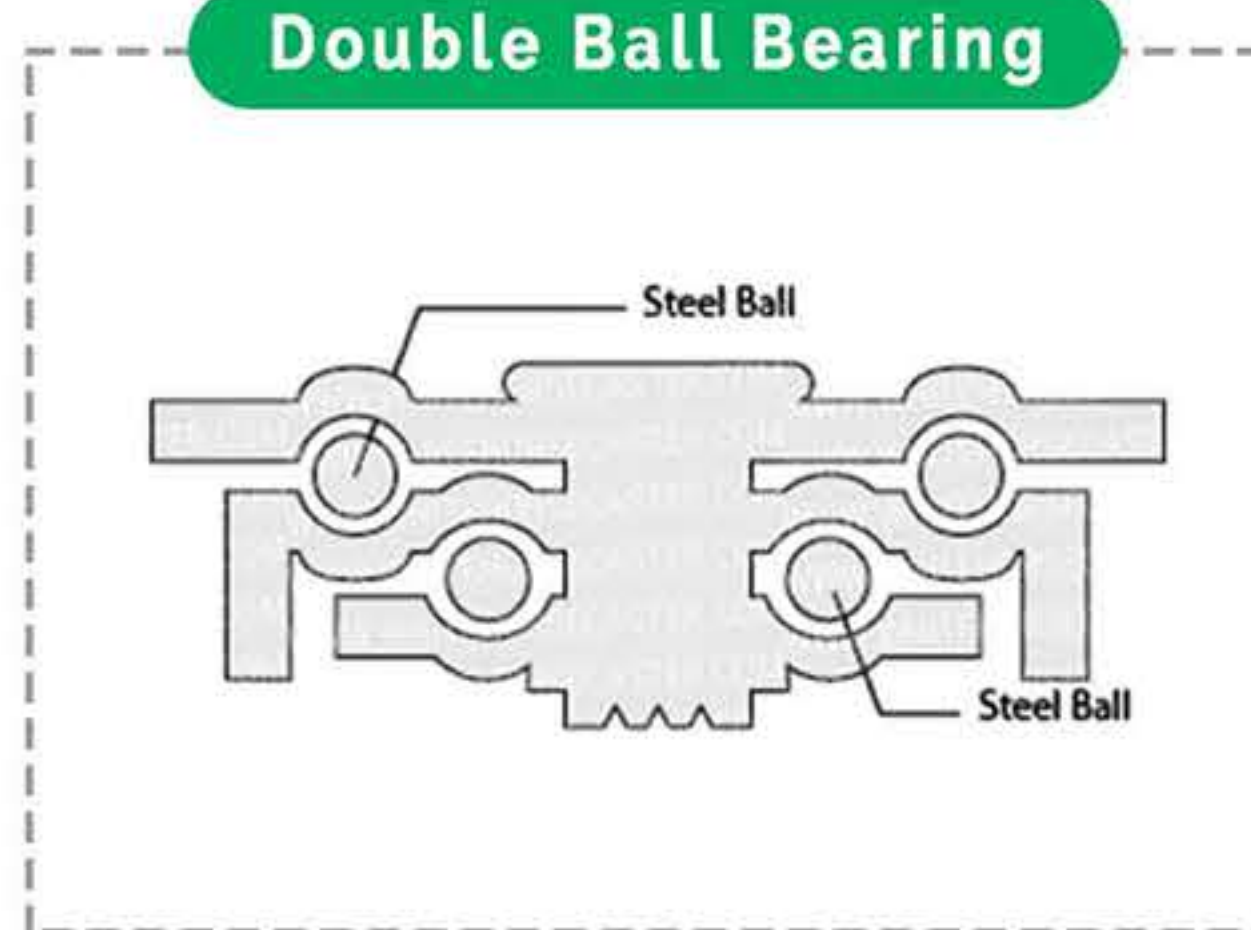

Wheel Option

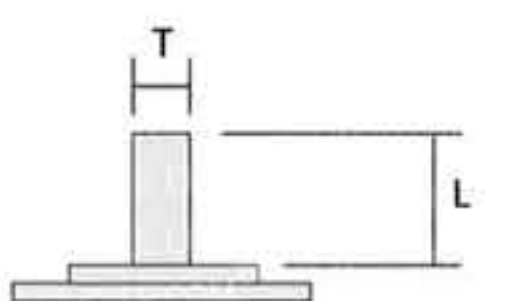
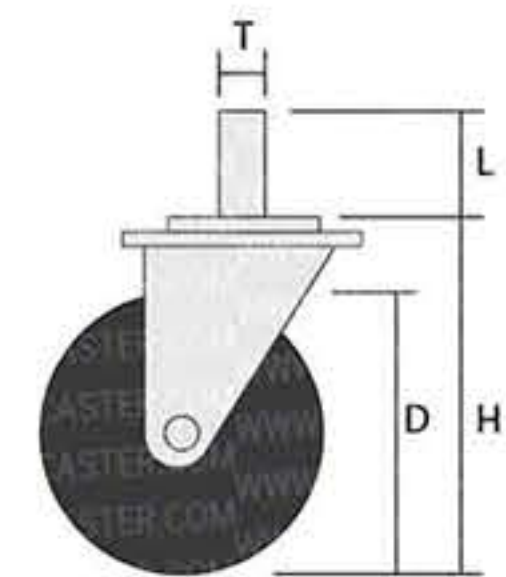
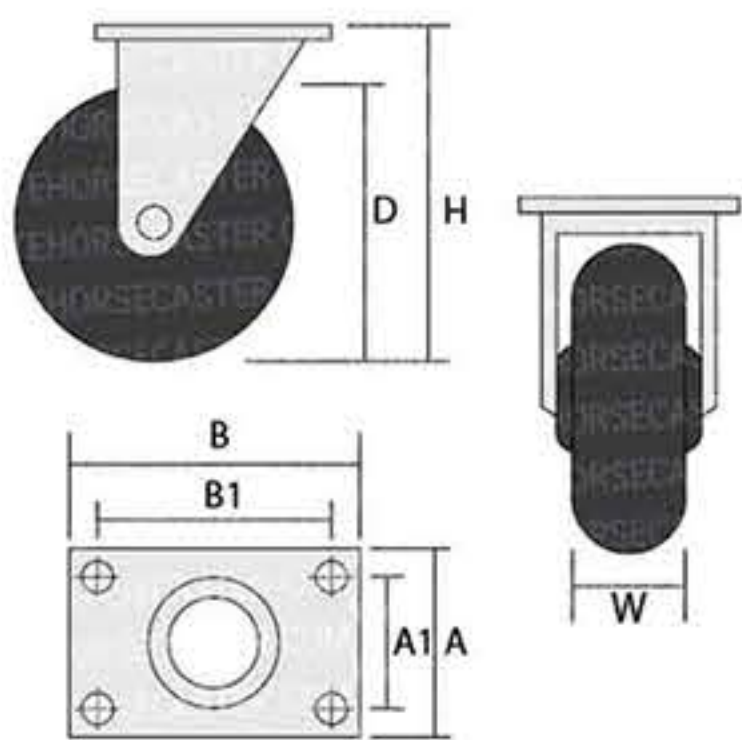
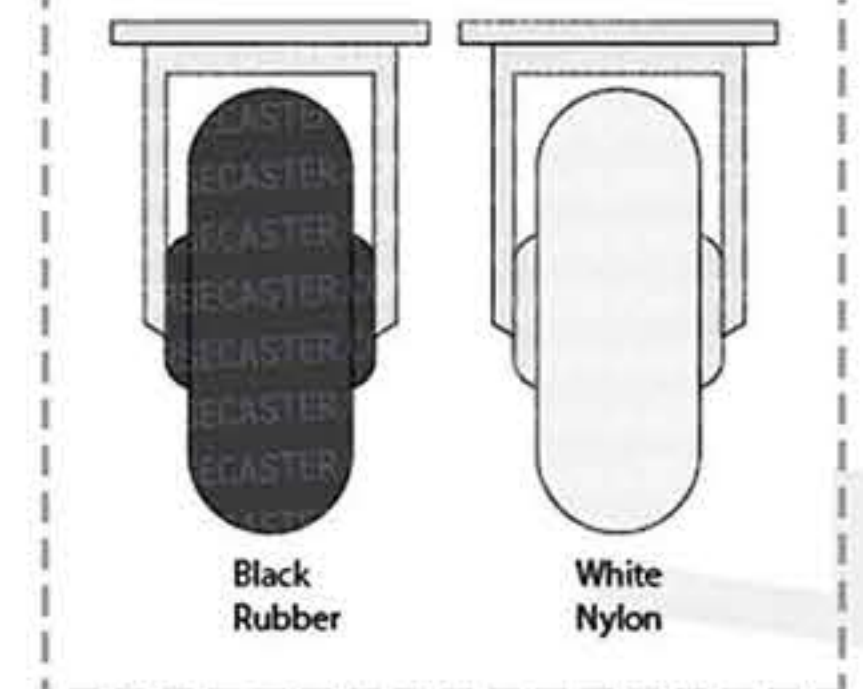

F/RB/S ; F/RB/SB							
Size (inch)	D (mm)	H (mm)	W (mm)	AxB (mm)	A1xB1 (mm)	Hole Diameter (mm)	Approx. Load Capacity (kg)
2"	50	65	20	42x70	28x56	6.5	30
2 ½"	65	82	22	42x70	28x56	6.5	30
3"	75	92	22	42x70	28x56	6.5	40

F/RB/X ; F/RB/XB							
Size (inch)	D (mm)	H (mm)	W (mm)	T Diamter x Pitch		L (mm)	Approx. Load Capacity (kg)
2"	50	68	20	M12x1.75	½"x20G	14	30
2 ½"	65	85	22	M12x1.75	½"x20G	14	30
3"	75	95	22	M12x1.75	½"x20G	14	40

F/RB/ST ; F/RB/STB							
Size (inch)	D (mm)	H (mm)	W (mm)	T (mm)	L (mm)	Approx. Load Capacity (kg)	
2"	50	64	20	11	38	30	
2 ½"	65	80	22	11	38	30	
3"	75	90	22	11	38	40	

ปลอกยางกันกระแทก
มั่นใจคุณภาพเก็ลียว



Proof of Genuine Product

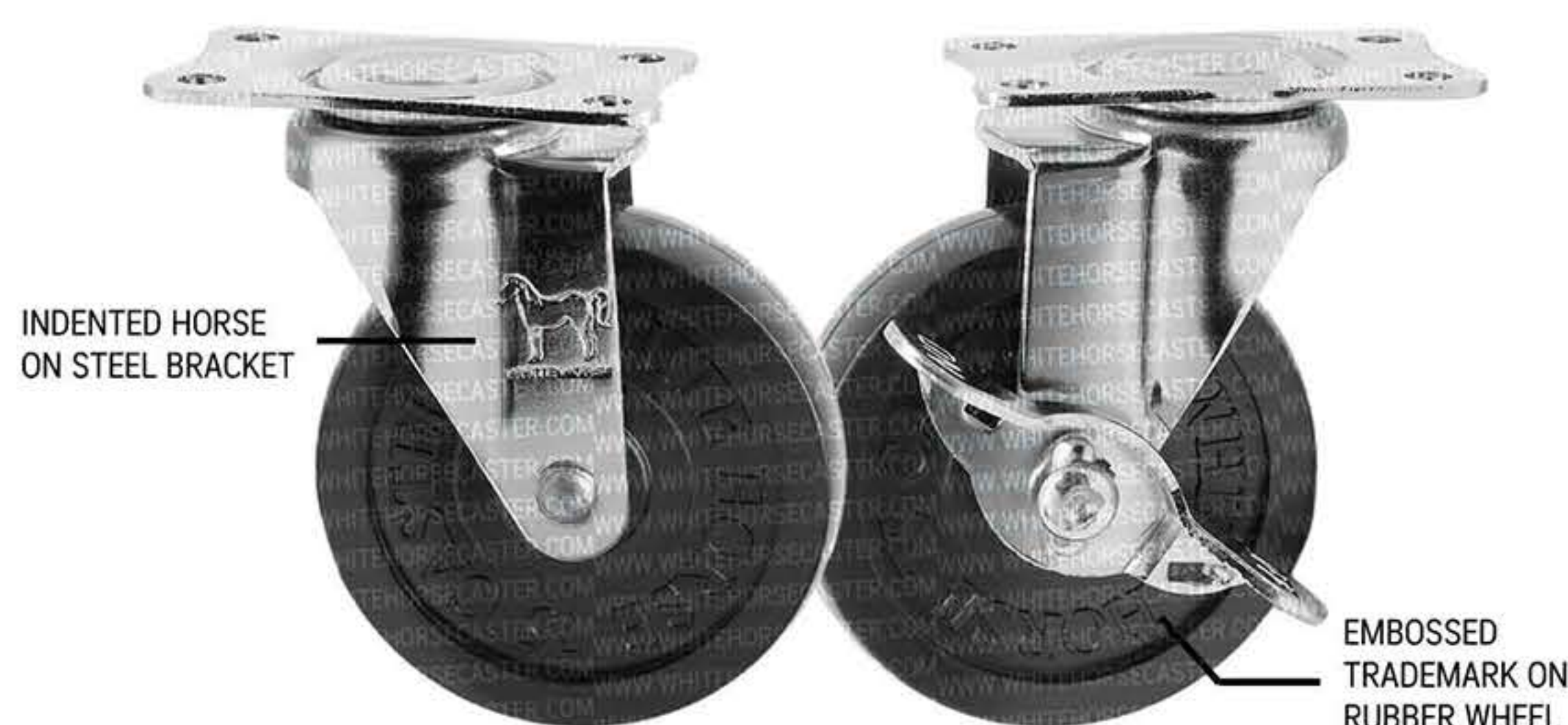



SERIES RUBBER / NYLON

Size: 2"-3" Load: 30-40 kg

WHITE HORSE
SUPER WHEEL



ผลิตจากยางธรรมชาติ มีความเหนียว
ทนทาน ไม่กรอบแตก ไม่ทำลายพื้น
หรือ ผลิตมาจากไนลอนพลาสติกคุณภาพสูง
ทนทานใช้ได้นาน ทนน้ำมัน ทนสารเคมี ทนร้อน



Tread: Natural Rubber / Nylon

Wheel Center: Natural Rubber / Nylon

Bearing: Plain Bushing

Options: Black Rubber / Natural White Nylon

Size (inch)	D (mm)	D1 (mm)	W (mm)	W1 (mm)	Load Capacity (kg)
2	50	6.8	20	22	30
2.5	65	6.8	22	23	30
3	75	6.8	22	23	40

Options:



BLACK RUBBER

NATURAL WHITE NYLON

